



SETTEMBRINO  
ARCHITECTS

25 Bridge Avenue, Suite 201  
Red Bank, NJ 07701  
(o) 732.741.4900  
(f) 732.741.4977  
www.settembrino.com

# ADDENDUM to CONTRACT DOCUMENTS

**Date:** 07.12.2019

**To:** All Bidders

**From:** Kevin M Settembrino, AIA, LEED AP

**Copies:** Monmouth County

**Project Name:** Monmouth County Seaview Building  
2047 NJ 66  
Ocean Township, NJ 07712

**Project Number:** SA # 16.013  
**RFB Number:** F-197-2018

**Subject:** **Addendum #2**

**NOTICE:**

Attention is called to the following item(s), effective as of the date above, which shall be added to, deleted from, or changed in the contract documents dated 01/10/2019, and any previously issued addenda, thereby incorporating these items into the contract documents.

Attach this Addendum to the project manual for this project. Work or materials not specifically mentioned herein are to be as described in the main body of the specifications and as shown on the drawings. Bidders shall acknowledge receipt of this Addendum in the space provided on the Bid Form. Failure to do so may subject the bidder to disqualification.

**A. GENERAL**

Item No.	Item
A-1	<b><u>Change to Bid Receipt Date</u></b> The bid receipt date for Interior Renovations and Alterations to the Monmouth County Seaview building has been change from July 17, 2019 to July 24, 2019 at 10:00 am.
A-3	<b><u>Addendum No. 1</u></b> Addendum No. 1 was issued on July 8, 2019, in the form of an email containing a link to download the Addendum in PDF format. The file can be downloaded by visiting <a href="https://www.dropbox.com/sh/owirt28tvu854z8/AADaT9odjg8R-zE1f0SXnODba?dl=0">https://www.dropbox.com/sh/owirt28tvu854z8/AADaT9odjg8R-zE1f0SXnODba?dl=0</a>

**B. MODIFICATIONS TO SPECIFICATIONS**

Item No.	Item
B-1	<b><u>Section 010100 – Summary of Work</u></b> Add the following: 1.2.c.8 Addendum No. 1 Item A-2 attached a Hazardous Material Survey dated May 11, 2018. That survey identifies certain asbestos-containing material. The Owner will provide technical specifications from the Owner’s environmental consultant for the abatement and/or containment of the asbestos containing material. Those documents will be distributed to the awarded contractor prior to the commencement of construction. The original bid form provides for an allowance of \$250,000.00, and bidders are to utilize that allowance to carry out abatement and/or containment of the asbestos containing material per the environmental consultant’s documents, on a time and material basis, and per Specifications section 010200.
B-2	<b><u>Section 10513 Metal Lockers</u></b> Heavy duty welded gear lockers as manufactured by “Locker Manufacturing Inc.” Germantown, TN. are considered equal to the “basis of design” locker manufacturer specified. Lockers to meet design as shown on the bid drawings and include all accessories as noted in specifications.

**C. MODIFICATIONS TO DRAWINGS**

Item No.	Item
C-1	<b><u>Addendum Drawing AD-2.1</u></b> Attached drawing clarifies the type of slip joint connection noted in section 092216 Non-Structural Metal Framing. This detail is to be used at all partitions attached to roof deck and / or roof joist.

**D. ATTACHMENTS**

- A. Drawing AD-2.1 – July 11, 2019

ATTACH TRACK TO STRUCTURE  
PER SPECIFICATION SECTION 092216

SLOTTED DEFLECTION TRACK  
MEMBER SIZE AS REQ'D  
TO ACCOMODATE STUD SIZE

GAP TO  
ALLOW FOR VERTICAL  
DEFLECTION.

(1)#8-18  
WAFFERHEAD  
FRAMING SCREWS  
IN EACH STUD  
FLANGE.

METAL STUDS SIZE, SPACING  
GAGE AS SPECIFIED

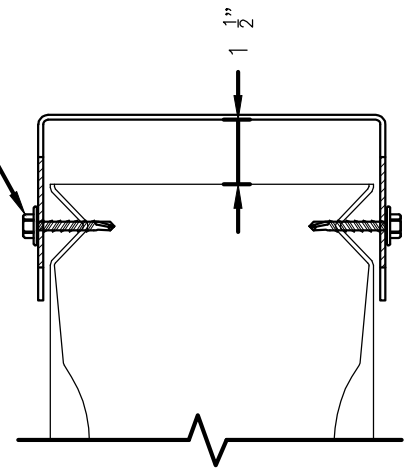

SIDE VIEW

Settembrino  
Architects, LLC  
25 Bridge Avenue  
Red Bank, NJ, 07701  
P 732.741.4900  
F 732.741.4977

Interior Renovations & Alterations  
to the Monmouth County  
Seaview Building  
2407 ROUTE 66  
OCEAN, NJ 07712

Drawn By: HP

Date Issued: 07.11.19

Scale: NTS

Project No.: 16-013

TOP OF METAL STUD:  
SLIP JOINT CONNECTION

Reference:

Drawing: AD-2.1